

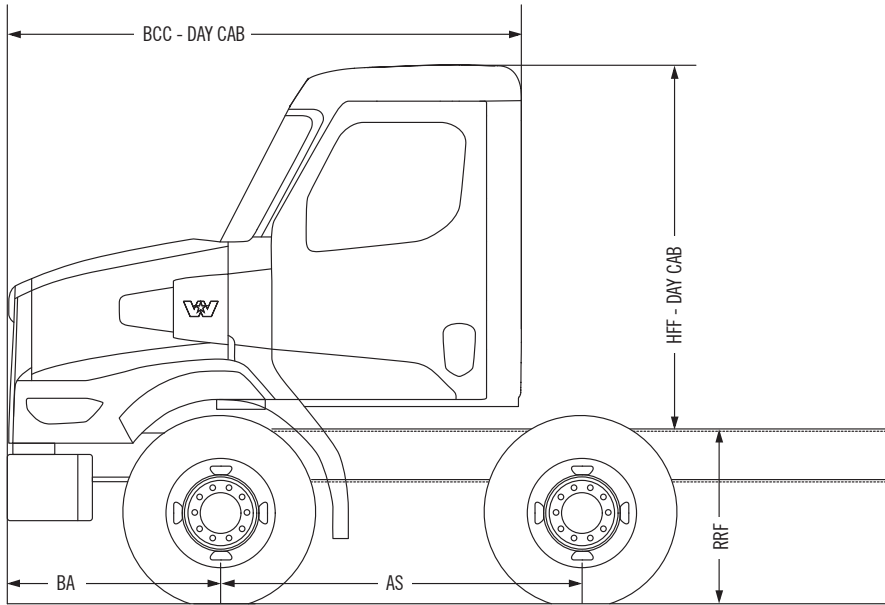

# WESTERN STAR 47X



CONFIGURATIONS	
STANDARD	8 X 4 TWIN STEER
GVM	GCM
28.5 TONNE GVM	UP TO 72.5 TONNE GCM
DESCRIPTION	
BA - BUMPER TO AXLE	
Bumper to axle	1,180
Axle spread	1,968
BBC - BUMPER TO BACK OF CAB	
Day cab	2,835
RRF - REAR FRAME HEIGHT - UNLADEN	
Airliner	1,056
HFF - HEIGHT FROM FRAME	
Day cab standard roof	1,942

## > CAB

STD	Steel reinforced day cab w/- aluminium roof 2,835 mm/111.6" BBC
OPT	Low trench style roof steel reinforced day cab w/- composite roof

## > AIR INTAKE

STD	Single side of hood air intake with engine mounted high capacity air cleaner and passive precleaner
-----	-----------------------------------------------------------------------------------------------------

## > ENGINE

STD	Detroit DD13 Gen 5 450 hp, 1,550 lb-ft Detroit - Jacobs Compression brake
OPT	Detroit DD13 Gen 5 470 hp, 1,650 lb-ft Detroit DD13 Gen 5 505 hp, 1,850 lb-ft Detroit DD13 Gen 5 525hp, 1,850 lb-ft

## > EXHAUST

STD	RH mid frame mounted ATD with RH horizontal tailpipe
-----	------------------------------------------------------

## > TRANSMISSION - AUTOMATIC

STD	Detroit DT12 AMT 1550 - OV 12 Speed transmission
OPT	Detroit DT12 AMT 1650 - OV 12 Speed transmission Detroit DT12 AMT 1750 - OV 12 Speed transmission Detroit DT12 AMT 1850 - OV 12 Speed transmission

## > TRANSMISSION - MANUAL

OPT	Eaton RTLO-16918B 1,650 lb-ft Eaton RTLO-18918B 1,850 lb-ft Eaton RTLO-20918B 2,050 lb-ft
-----	-------------------------------------------------------------------------------------------------

## > FRONT AXLE

STD	Meritor MFS-14-143A 13.3t 3.5" drop tandem front axles
-----	--------------------------------------------------------

## > FRONT SUSPENSION

STD	Tandem taperleaf spring 13.2 t capacity, load sharing
-----	-------------------------------------------------------

## > REAR AXLE

STD	Meritor MT44-14X 19.95 t GAWR tandem
OPT	Meritor MT40-14XGP 18.1 t GAWR tandem Meritor RT-46-160GP 20.9 t GAER tandem

## > REAR SUSPENSION

STD	Airliner 18.1 t GAWR air bag tandem
OPT	Airliner 20.9 t GAWR air bag tandem

## > BRAKES

STD	Bendix Air Disc
-----	-----------------

## > UPFIT EFFICIENCY SYSTEMS

STD	<ul style="list-style-type: none"> <li>Advanced multiplexed electrical system for easy truck equipment interface:                             <ul style="list-style-type: none"> <li>– Hard wired dash mounted auxiliary switches</li> <li>– Prep for customer supplied PTO</li> <li>– Prep for remote Engine control with park brake interlock</li> <li>– RP1226 telematics connector to J1939 network for customer fit telematics</li> </ul> </li> </ul>
OPT	<ul style="list-style-type: none"> <li>Manufacturer body builder interface, programming and power access Auxiliary in-cab or sleeper mounted e-vault available, which houses:                             <ul style="list-style-type: none"> <li>– QuickFit programmable controllers</li> <li>– QuickFit interface connectors</li> <li>– TEM-specific power distribution module</li> <li>– High-current power access</li> </ul> </li> </ul>

## > ELECTRICAL SYSTEM

STD	12 Volt System 160 amp Alternator Detroit Mitsubishi 12V Mod 31 755-DP60
-----	--------------------------------------------------------------------------------

## > SAFETY SYSTEMS

STD	With Detroit DD13 Engines and Detroit DT12 Transmissions: Detroit Assurance® Safety Systems including: <ul style="list-style-type: none"> <li>• Active Brake Assist 5</li> <li>• Adaptive cruise control to 0 kms with adj headway</li> <li>• Lane departure warning</li> <li>• Automatic wipers/headlamps</li> <li>• Intelligent high beam control</li> <li>• Brake hold</li> <li>• Electronic stability control</li> <li>• Anti-lock braking system</li> <li>• Detroit Connect and Virtual Technician platform hardware</li> <li>• Detroit Connect Safety Event Viewer package</li> <li>• Pre-Trip Inspection feature for exterior lamps</li> <li>• Alarm for door open, park brake not set</li> </ul>
OPT	With manual transmissions all of the above except: <ul style="list-style-type: none"> <li>• Standard (adaptive) cruise control</li> <li>• No brake hold</li> <li>• Optional lane departure warning</li> <li>• Optional side guard assist</li> </ul>

## > SECURITY

OPT	Remote keyless entry
-----	----------------------

## > DRIVER INFORMATION MODULE

STD	Premium instrument cluster with 125 mm TFT colour display with controls on steering wheel
OPT	Digital dash displays with 300 mm centre panel cluster and 250 mm B-panel infotainment display DT12 transmission only

## > DRIVERS SEATS

STD	ISRI high back air suspension seat with integrated 3 point seat belt
OPT	Rolltek Gen 2 air bag integrated into std ISRI seat ISRI Premium 2.0 high back air suspension seat with swivel base and non-integrated seat belts

## > PASSENGER SEATS

STD	Sears tool box high back non suspension seat
OPT	ISRI high back air suspension seat with integrated 3 point seat belt ISRI Premium 2.0 high back air suspension seat with swivel base and non-integrated seat belts Battery box mid back non suspension seat

## > WHEELS

STD	No front wheel polishing
OPT	Polished aluminium disc 10 stud Dura-Bright wheel finish

## > FUEL TANKS

STD	Round 635 mm diameter 227 L to 567 L*
OPT	Square (LCS) 735 mm x 700 mm 320 L to 775 L *Various fuel and hydraulic tank combinations available

## > DEF TANKS

STD	49L diesel exhaust fluid tank
OPT	87L diesel exhaust fluid tank

## > PAINT

STD	Single colour cab. Cab - one colour basecoat/clearcoat, Chassis - one colour basecoat/clearcoat
OPT	Up to 4 colours. Base coat/Clearcoat solid colour, metallic or pearl

# STAR ASSIST™

No matter where you are, we can get you going – 24 hour road assistance.

**1800 247 WSTAR**  
1800 247 97827