

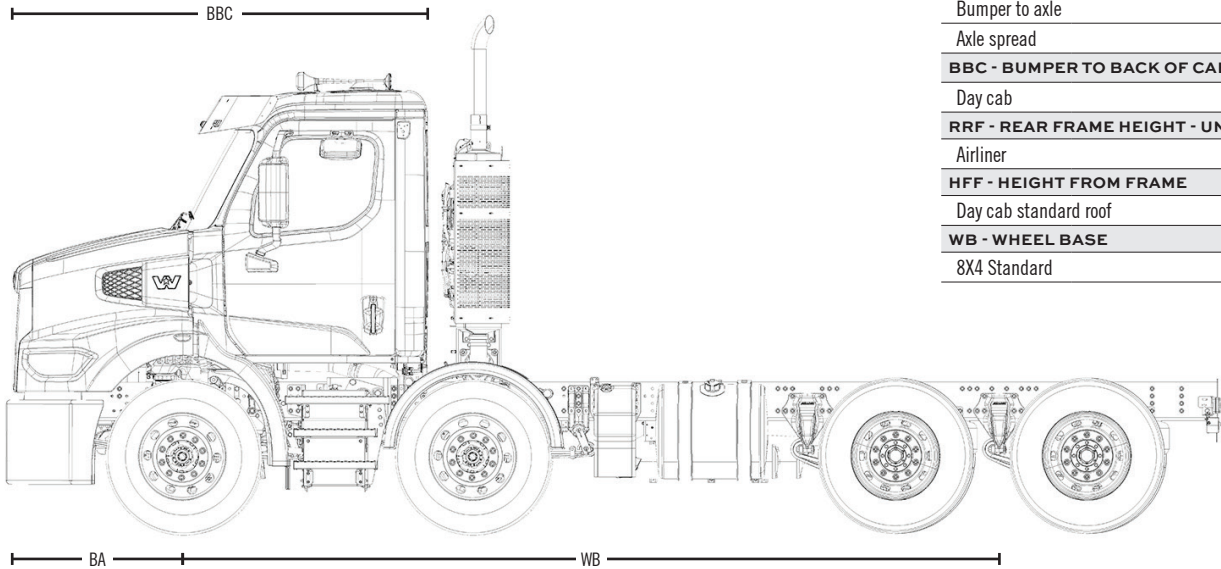

WESTERN STAR 47X



CONFIGURATIONS	
STANDARD	8 X 4 TWIN STEER
GVM	
NOMINAL 28.5 TONNE GVM * HIGHER ON APPLICATION	
DESCRIPTION	MM
BA - BUMPER TO AXLE	
Bumper to axle	1,180
Axle spread	1,968
BBC - BUMPER TO BACK OF CAB	
Day cab	2,835
RRF - REAR FRAME HEIGHT - UNLADEN	
Airliner	1,056
HFF - HEIGHT FROM FRAME	
Day cab standard roof	1,942
WB - WHEEL BASE	
8X4 Standard	5,475

> CAB

STD Steel reinforced day cab w/- aluminium roof
2,835 mm/111.6" BBC

> AIR INTAKE

STD Single side of hood air intake with engine mounted high capacity air cleaner and passive precleaner

> ENGINE

STD Cummins L9 330 hp, 1,000 lb-ft
Cummins Engine brake - C-Brake by Jacobs

OPT Cummins L9 350 hp, 1,050 lb-ft

> EXHAUST

STD LH frame mounted vertical ATS with std top stack

> TRANSMISSION - AUTOMATIC

STD Allison 3000 RDS Series with PTO provision and auto-neutral functions

> PTO

STD Prep for C/F Chelsea PTO
Remote Engine interface for remote throttle
PTO controls for enhanced vehicle electronic architecture

OPT Chelsea PTO CHL870XEFJP B5XV

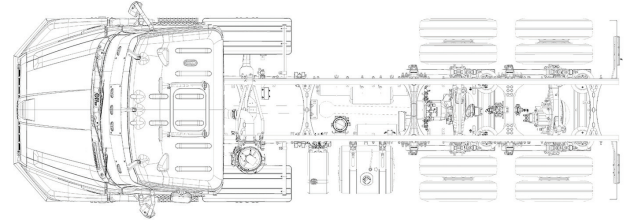

> FRONT AXLE

STD Meritor MFS-14-143A 13.3t 3.5" drop tandem front axles

> FRONT SUSPENSION

STD Tandem taperleaf spring 13.2 t capacity, load sharing

> REAR AXLE

STD Meritor MT40-14XGP 18.1 t GAWR tandem
Driver control traction lock, both axles
6.14 Axle Ratio

OPT Meritor MT44-14X 19.95 t GAWR tandem

> REAR SUSPENSION

STD Airliner 20.9 t GAWR air bag tandem suspension

> BRAKES

STD Bendix Air Disc

> UPFIT EFFICIENCY SYSTEMS

STD	<ul style="list-style-type: none"> Advanced multiplexed electrical system for easy truck equipment interface: <ul style="list-style-type: none"> – Hard wired dash mounted auxiliary switches – Prep for customer supplied PTO – Prep for remote Engine control with park brake interlock – RP1226 telematics connector to J1939 network for customer fit telematics – Manufacturer body builder interface, programming and power access Auxiliary in-cab e-vault, which houses: <ul style="list-style-type: none"> – QuickFit programmable controllers – QuickFit interface connectors – TEM-specific power distribution module – High-current power access
-----	---

> ELECTRICAL SYSTEM

STD	12 Volt System 160 amp Alternator Delco 12V 39 MT HD/OCP Starter
-----	--

> SAFETY SYSTEMS

STD	Detroit Assurance® Safety Systems including: <ul style="list-style-type: none"> • Active Brake Assist 5 • Lane departure warning • Standard cruise control with controls on steering wheel • Electronic stability control • Anti-lock braking system • Pre-Trip Inspection feature for exterior lamps • Alarm for door open, park brake not set
-----	--

> SECURITY

STD	Remote keyless entry
-----	----------------------

> DRIVER INFORMATION MODULE

STD	Premium instrument cluster with 125 mm TFT colour display with controls on steering wheel
-----	---

> DRIVERS SEATS

STD	ISRI high back air suspension seat with integrated 3 point seat belt
OPT	Rolltek Gen 2 air bag integrated into std ISRI seat ISRI Premium 2.0 high back air suspension seat with swivel base and non-integrated seat belts

> PASSENGER SEATS

STD	Sears tool box high back non suspension seat
-----	--

> WHEELS

STD	No front wheel polishing
OPT	Polished aluminium disc 10 stud Dura-Bright wheel finish

> FUEL TANKS

STD	Round 635 mm diameter 189 L mounted LHS
OPT	Round 635 mm diameter 227 L mounted LHS

> PAINT

STD	Single colour cab. Cab - one colour basecoat/clearcoat, Chassis - one colour basecoat/clearcoat
OPT	Up to 4 colours. Base coat/Clearcoat solid colour, metallic or pearl

STAR ASSIST™

No matter where you are, we can get you going – 24 hour road assistance.

1800 247 WSTAR
1800 247 97827

MANUFACTURERS' WARRANTY

100% PARTS AND LABOUR

36 months or,
350,000 kilometres or,
8,650 hours*

