

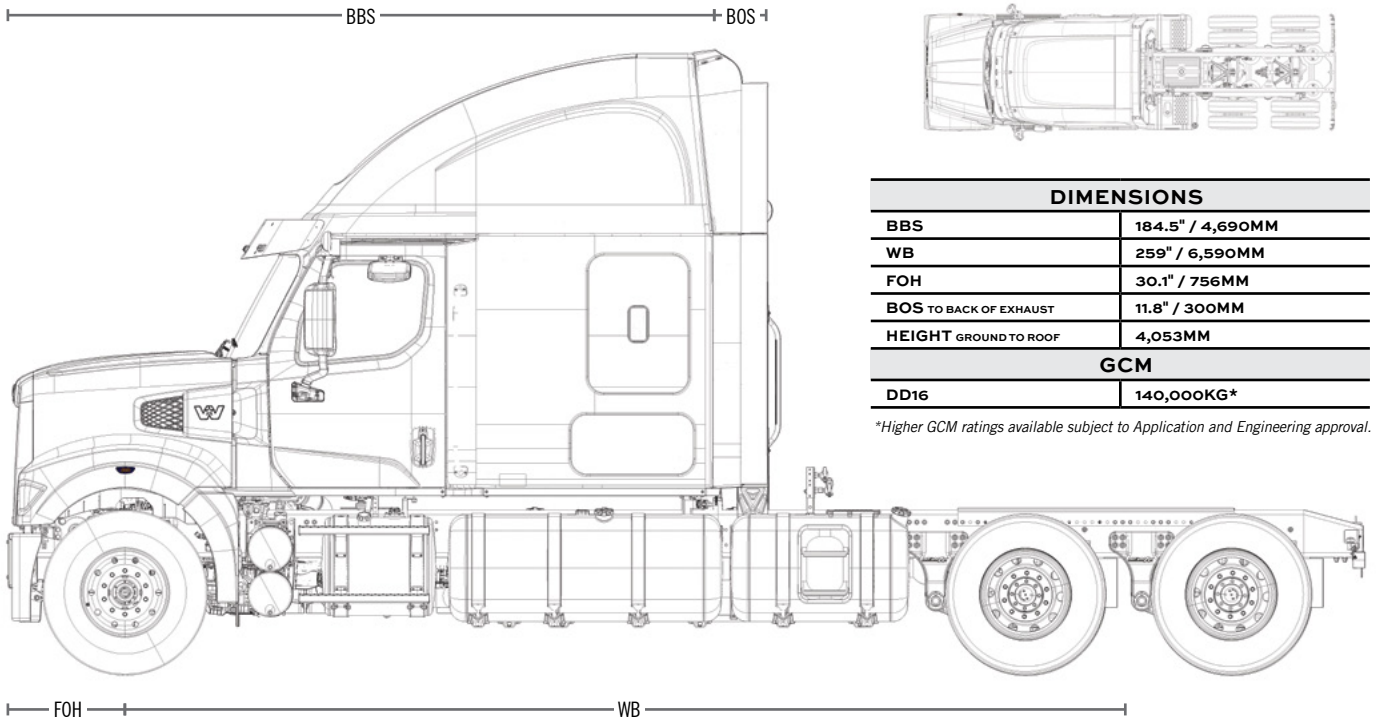

ROADTRAIN

72" STRATOSPHERE SLEEPER, DD16



DIMENSIONS	
BBS	184.5" / 4,690MM
WB	259" / 6,590MM
FOH	30.1" / 756MM
BOS TO BACK OF EXHAUST	11.8" / 300MM
HEIGHT GROUND TO ROOF	4,053MM
GCM	
DD16	140,000KG*

*Higher GCM ratings available subject to Application and Engineering approval.

> CAB

- STD** 121.5" BBC X-Series steel-reinforced aluminium cab
 70 Degree opening X-Series steel doors
 Air cab mounting
 RH/LH electric powered windows
 Remote key-less entry, and 2 transmitter
 Black C-bar mirror system with electric RH/LH, door mounted
 One-piece roped-in windshield
 Four spoke 450mm leather wrapped steering wheel with chrome switch bezels
- SLEEPER**
 72" X-Series Stratosphere high roof sleeper
 20" Cab/ sleeper cab side extenders with black flexible ends
 40" wide 8" thick inner spring mattress, liftable
 LH and RH luggage doors
 Fold-able upper inner spring mattress with removable cover
 Digital alarm clocks in driver display and flush mounted in sleeper
 Tall closet with writing surface and upper storage in sleeper
 Microwave shelf with upper storage
 Factory installed 65L fridge freezer with thermostat and interior light
 Auxiliary heater/air conditioner with outlet temperature control

> UPFIT EFFICIENCY FEATURES

- STD** Advanced multiplexed electrical system for easy truck equipment,
 • Hard wired dash mounted auxiliary switches
- OPT** Manufacturer body builder interface, programming and power access
 Auxiliary in-cab mounted e-vault available, which houses:
 • QuickFit programmable controllers
 • QuickFit interface connectors
 • TEM-specific power distribution module
 • High-current power access

> INTERIOR TRIM

- STD** **X-SERIES PREMIUM:**
 • Black Laredo leather seats
 • Extreme insulation
 • Premium LED cab lighting
 • Bright finish dash gauge bezels
 • Timber brown interior colour

> ENGINE

- STD** Detroit® DD16®, 600 HP, 2,050 lb-ft
 34.8 CFM dual cylinder air compressor
 Jacobs compression brake
 215 AMP brush-less alternator
 RH outboard under step mounted horizontal DPF ATD/ATS
 Mitsubishi 12V MOD 3.175-DP60 starter integrated magnetic switch

> **AIR INTAKE**

STD Dual air intake through side bonnet mounted hi air rams, engine mounted high capacity air cleaner and dual passive precleaners

> **X-SERIES COOLING PACKAGE**

STD 1,600 square inch X-Series aluminium radiator
e-Viscous fan clutch
Gates blue stripe coolant hoses
OAT Nitrate free long life coolant
2 piece radiator shroud
Radiator rock guard

> **TRANSMISSION**

STD Eaton Fuller RTLO-22918B
Aluminium clutch housing
Hydraulic clutch control
Chromed shift lever, solid linkage
Air to oil transmission cooler
Synthetic transmission oil

> **BONNET 'POWER HOOD'**

STD Impact-resistant, durable, moulded resin bonnet with high-visibility design
ISO TECH bonnet suspension system
Standard with locking bonnet strut

> **GRILLE**

STD Radiator-mounted stainless steel grille with stainless steel bezels surrounds

> **HVAC**

STD HVAC with 5 face outlets, 4 floor outlets,
2 side window defrost outlets and 10 blower speeds

> **FRAME**

STD Single-channel 13.0mm X 87.0mm X 311.0mm (0.51"x3.43"x12.24")
1,525mm rear frame overhang with rear tow pin and clevis
4 x AGM starting & cycling min 920CCA, 760RC, threaded stud mounted in chassis rail BOS
Positive & negative posts for jumpstart located on frame next to starter
1/2"x3-7/8"x4" mounting angle for Australian furnished fifth wheel

> **TYRES AND WHEELS**

STD FRONT - Michelin X Multi HLZ 385/65R22.5 20 PLY radial front tyres
REAR - Michelin X Multi D 11R22.5 16 PLY radial rear tyres
FRONT - Alcoa LVL One 22.5X12.25 4.68 inset 10-hand aluminum dura-bright finish
REAR - Alcoa LVL One 22.5X8.25 aluminum disc rear wheels with dura-bright outers

> **FRONT AXLE**

STD Meritor FL/941 9,071kg single front axle
Conmet preset plus premium iron front hubs

> **FRONT SUSPENSION**

STD 8,164 kgs taperleaf front suspension with maintenance free bushes

> **REAR SUSPENSION**

STD Neway ADZ 252 23,586 kgs tandem rear axle and rear air suspension

> **REAR AXLES**

STD DANA Spicer D52-190P 23,586 kgs T-Series rear axle, 4.30 rear axle ratio, optional based on application
Driver controlled traction control for both tandem axles
SPL250 HT XL Dana Spicer main driveline 'SF' service free
SPL170 XL Dana Spicer interaxle driveline 'SF' service free
Conmet preset plus premium iron rear hubs

> **BRAKE SYSTEM**

STD Meritor 16.5X Q+ cast spider cam front brakes, double anchor, fabricated shoes with Haldex automatic front slack adjusters with enhanced stability control
WABCO twin air dryer with heater

> **ACTIVE SAFETY**

STD Detroit Assurance® suite of safety systems including: Active brake assist 5, adaptive cruise control to 0 KM/H, lane departure warning, automatic headlights/wipers and intelligent high beams

> **SEATS**

STD ISRI high back air suspension driver and passenger seats with integrated seatbelt, and two-stage lumbar internal cushion
Extendable and tilting seat with adjustable shock absorber

> **EXHAUST**

STD Dual curved vertical tailpipes back of cab frame mounted with chrome elbows and 5" chrome stacks

> **FUEL TANKS**

STD **SQUARE TANKS:**
• RH: 745 litres and 360 litres
• LH: 745 litres and 490 litres
Note: Locking fuel caps
Machine finished fuel tanks and polished stainless steel straps

> **DEF TANK**

STD 200 litres
Polished stainless steel round AdBlue tank with stainless steel straps