

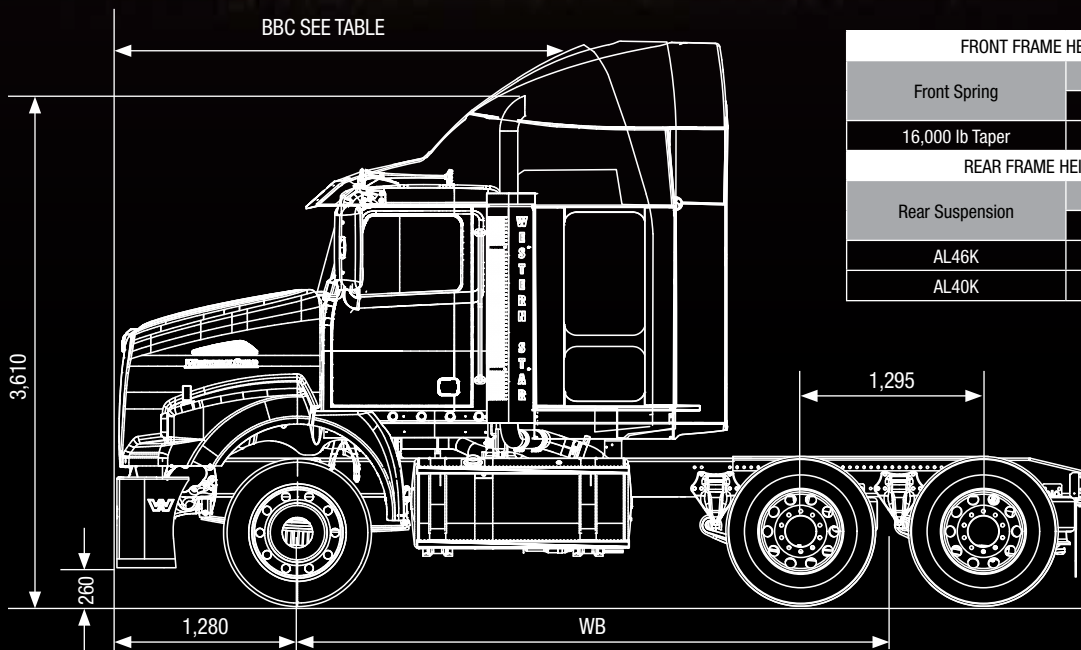

SPECIFICATIONS



FRONT FRAME HEIGHT (F.F.H) mm		
Front Spring	Tyres	
	295/80R22.5	385/65R22.5
16,000 lb Taper	1,065	1,065
REAR FRAME HEIGHT (R.F.H) mm		
Rear Suspension	Tyres	
	11R22.5	
AL46K	1,060	
AL40K	1,015	

BBC Dimensions	
Cab Type	BBC mm
Day Cab	2,777
34" Flat	3,590
34" Strat	3,430
40" Strat	3,600
54" Strat	3,957



SPECIFICATIONS & OPTIONS

ENGINE	
Engine & HP/RPM, Torque	Detroit DD13 12.8L 450 hp; 1,550 lb-ft up to 1,650 lb-ft Option: DD15 475 hp up to 560 hp; 1,650 lb-ft up to 1,850 lb-ft
ENGINE EQUIPMENT	
Air Intake	Donaldson air intake on sides of bonnet
Engine Brake	DD13/DD15 - Jacobs compression brake
Engine Fan Drive	Borg Warner (Kysor) Option: Horton two-speed Drivemaster
Radiator	1,700 square inch aluminium
Starter	DD15 - Mitsubishi Mod 31 75-DP60 with integrated magnetic switch
TRANSMISSION	
Transmission	Eaton Fuller manual, Ultrashift AMT and Allison automatic
AXLE & SUSPENSION	
Front Axle	Meritor MFS-16-122A FL1 (MFS73), 16,000 lb axle capacity Option: Meritor FG-941, 14,600 lb axle capacity
Front Slack Adjusters	Meritor automatic; options available
Front Suspension	16,000 lb capacity taper-leaf, options available
Rear Axle	Meritor MX-40-14XGP R-series rear axle, options available
Rear Axle Ratio	4.33 – optional based on application
Main Driveline	Meritor RPL 25SD, option: Dana Spicer SPL250HD
Interaxle Driveline	Meritor RPL 20SD, option: Dana Spicer SPL170HD
Rear Slack Adjusters	Meritor automatic; options available
Rear Suspension	Airliner extra duty 40,000 lb capacity; options available
BRAKE SYSTEM	
Anti-Lock (ABS)	WABCO 4S/4M with traction control enhancement
Air Dryer	WABCO system saver HP with integral air governor and heater
Roll Stability Control	Optional WABCO roll stability control - based on application
FRAME	
Frame Rails	5/16" X 3-1/2" X 10-5/8" steel frame, 120ksi; options available
Wheelbase	Options from 4,225 mm (166") to 6,050 mm (238")

CHASSIS EQUIPMENT	
Fuel Tanks	25" diameter aluminium, EquiFlo, 2 x 378L; options available
Fuel/Water Separator	Davco 487 with ESOC
Fuel Cooler	Steel core chassis mounted, in frame
WHEELS & TYRES	
Front Tyres	Michelin X Multiway 3D XZE 295/80R22.5 16 ply radial Option: Michelin X Multiway HD XZE 385/65R22.5 20 ply radial
Rear Tyres	Michelin X Multiway D 11R22.5 16 ply radial - Tandem Option: Alcoa 88367X 22.5" x 8.25" 10-hub piloted, aluminium disc with Dura-Bright
CABIN EXTERIOR	
Cabin	109" BBC galvanised steel cab, ECE R29 compliant, setback axle
Sleeper	Day cabin Option: 34" Star light low roof sleeper 34" Stratosphere high roof rest cab 40", 54" Stratosphere sleeper high rise stand up cab and walk-through
Headlights	Dual rectangular Bosch
Primary Mirrors	Moto - dual stainless steel heated left and right-hand motorised mirrors with lights and remote Option: cab mounted - dual Mekra aero bright finish heated dual axis one-piece motorised mirrors with lights, LH and RH remote and integral convex mirrors
Mirror Mtd Aux Mirrors	Left-hand and right-hand 8" convex mirrors, bright finish Option: dual Mekra bright finish heated convex mirrors with manual adjustment and dual axis for one-piece primary mirrors
Door Window Regulators	Left and right-hand electric powered windows
Exterior Sunvisor	Fibreglass on day cabs and stainless steel with Stratosphere sleeper cabs
CABIN INTERIOR	
Heater, Vent, AC	Heater, defroster & air conditioner with constant temperature control & cosmetic cover
INSTRUMENTS & CONTROLS	
Driver Info Centre	DataStar driver display and warning lamp/light bar display, non-data linked
PAINT	
Cabin	PPG white with base coat clear - options available
Chassis	PPG single stage - colour options available



Western Star Trucks is a premier producer of hand-built heavy-duty trucks, engineered for the toughest vocations. To learn more about the different options and the range, contact your local Western Star dealer or visit WESTERNSTAR.COM.AU

PENSKE AUSTRALIA • 72 FORMATION STREET WACOL QLD 4076 • PHONE (07) 3271 7777

Dimensions for frame height are all to the top of the chassis above axle (group) centreline and may vary based on frame depth. For illustration purposes different configurations have been used. Due to optional equipment, variable fuel quantity, and therefore tare weight, the variations will occur in the heights. For specific heights please contact your Western Star dealer. On heavy duty trucks, height variations in the order of +/- 25mm can be expected. Heights have been calculated with trucks unladen with Michelin tyres unless specified. Use of tyres by different manufacturers will result in height variations. Contact your Western Star dealer for a full range of options. Specifications may be subject to change.