

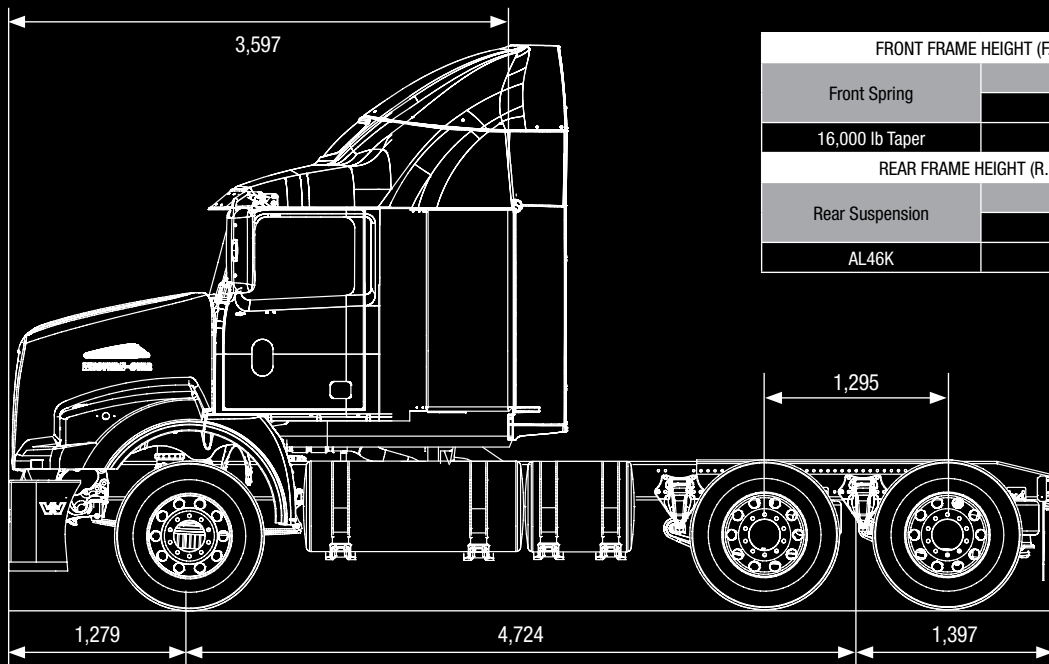

SPECIFICATIONS



| FRONT FRAME HEIGHT (F.F.H) mm | |
|-------------------------------|----------------------|
| Front Spring | Tyres 295/80R22.5 |
| 16,000 lb Taper | 1,058 |
| REAR FRAME HEIGHT (R.F.H) mm | |
| Rear Suspension | Tyres 11R22.5 |
| AL46K | 1,056 |



SPECIFICATIONS & OPTIONS

| ENGINE | |
|-------------------------|---|
| Engine & HP/RPM, Torque | Detroit DD15 500 hp up to 560 hp, 1,650 lb-ft up to 1,850 lb-ft |
| ENGINE EQUIPMENT | |
| Air Intake | Donaldson air intake on sides of bonnet |
| Engine Brake | Jacobs compression brake |
| Engine Fan Drive | Borg Warner (Kysor) Option: Horton two-speed Drivemaster |
| Radiator | 1,700 square inch aluminium |
| Exhaust | RH inboard frame mounted horizontal tailpipe with mitigator |
| Starter | Mitsubishi Mod 31 75-DP60 with integrated magnetic switch |
| TRANSMISSION | |
| Transmission | Eaton Fuller manual and Ultrashift AMT |
| AXLE & SUSPENSION | |
| Front Axle | Meritor MFS-16-122A FL1 (MFS73) front axle, 16,000 lb axle capacity |
| Front Suspension | Taper-leaf 16,000 lb capacity |
| Rear Axle | Meritor RT-46-160GP, 46,000 lb axle capacity |
| Rear Axle Ratio | 4.30 – optional based on application |
| Main Driveline | Meritor RPL 25SD, option: Dana Spicer SPL250HD |
| Interaxle Driveline | Meritor RPL 20SD, option: Dana Spicer SPL170HD |
| Rear Suspension | Airliner 46,000 lb capacity |
| BRAKE SYSTEM | |
| Anti-Lock (ABS) | WABCO 4S/4M with traction control enhancement |
| Air Dryer | WABCO system saver HP with integral air governor and heater |
| Roll Stability Control | Optional WABCO roll stability control - based on application |
| FRAME | |
| Frame Rails | 3/8" x 3-1/2" x 10-3/4" steel frame, 120 ksi |
| Wheelbase | 4,725 mm (186") |
| CHASSIS EQUIPMENT | |
| Fuel Tanks | 25" diameter aluminium, EquiFlo, 1,400L |
| Fuel Cooler | Steel core chassis mounted, in frame |

| WHEELS & TYRES | |
|------------------------|--|
| Front Tyres | Michelin X Multiway 3D XZE 295/80R22.5 16 ply |
| Rear Tyres | Michelin X Multiway D 11R22.5 16 ply |
| Wheels | Alcoa 22.5" x 8.25" 10-hub piloted, aluminium disc wheels, Dura-Bright finish |
| CABIN EXTERIOR | |
| Cabin | 109" BBC galvanised steel cab, ECE R29 compliant, setback axle |
| Sleeper | 40" Stratosphere high rise stand up cab and walk-through |
| Roof Fairing | Western Star roof fairing with cabin side extenders |
| Primary Mirrors | Moto - dual stainless steel heated left and right-hand motorised mirrors with lights and remote. Option: cab mounted - dual Mekra aero bright finish heated dual axis one-piece motorised mirrors with lights, LH and RH remote and integral convex mirrors |
| Mirror Mtd Aux Mirrors | Left-hand and right-hand 8" convex mirrors, bright finish. Option: dual Mekra bright finish heated convex mirrors with manual adjustment and dual axis for one-piece primary mirrors |
| Door Window Regulators | Left and right-hand electric powered windows |
| CABIN INTERIOR | |
| Seats | National 2000 Series high-back driver seat with six-way front and rear cushions. All seats with Laredo leather covers |
| Seat Armrests | Dual armrests for driver seat only |
| Heater, Vent, AC | Heater, defroster and air conditioner with constant temperature control |
| INSTRUMENTS & CONTROLS | |
| Driver Info Centre | DataStar driver display and warning lamp/light bar display, non-data linked |
| PAINT | |
| Cabin | PPG white with base coat clear - options available |
| Chassis | PPG single stage - colour options available |



Western Star Trucks is a premier producer of hand-built heavy-duty trucks, engineered for the toughest vocations. To learn more about the different options and the range, contact your local Western Star dealer or visit WESTERNSTAR.COM.AU

PENSKE AUSTRALIA • 72 FORMATION STREET WACOL QLD 4076 • PHONE (07) 3271 7777

Dimensions for frame height are all to the top of the chassis above axle (group) centreline and may vary based on frame depth. For illustration purposes different configurations have been used. Due to optional equipment, variable fuel quantity, and therefore tare weight, the variations will occur in the heights. For specific heights please contact your Western Star dealer. On heavy duty trucks, height variations in the order of +/- 25mm can be expected. Heights have been calculated with trucks unladen with Michelin tyres unless specified. Use of tyres by different manufacturers will result in height variations. Contact your Western Star dealer for a full range of options. Specifications may be subject to change.