

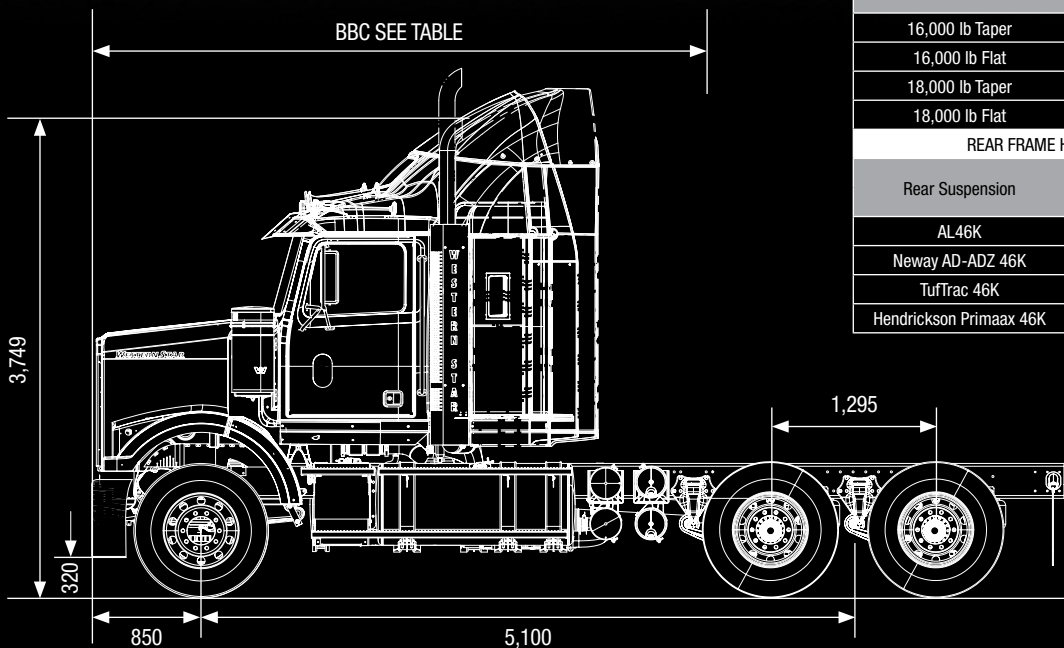

# SPECIFICATIONS



FRONT FRAME HEIGHT (F.F.H) mm*		
Front Spring	Tyres	
	295/80R22.5	385/65R22.5
16,000 lb Taper	1,065	1,084
16,000 lb Flat	1,065	1,084
18,000 lb Taper	1,065	1,084
18,000 lb Flat	1,126	1,145
REAR FRAME HEIGHT (R.F.H) mm		
Rear Suspension	Tyres	
	11R22.5	
AL46K	1,060	
Neway AD-ADZ 46K	1,060	
TufTrac 46K	1,087	
Hendrickson Primaax 46K	1,060	

BBC Dimensions	
Cab Type	BBC mm
Day Cab	2,271
34" Flat	3,599
34" Strat	3,458
40" Strat	3,623
54" Strat	3,970
68" Strat	4,350

\*Higher GCM ratings available subject to application and engineering approval.



# SPECIFICATIONS & OPTIONS

ENGINE	
Engine & HP/RPM, Torque	Detroit DD13 450 hp @ 1,800 rpm; 1,550 lb-ft up to 1,650 lb-ft @1200 rpm Option: DD15 475 hp up to 560 hp, 1,650 lb-ft up to 1,850 lb-ft
ENGINE EQUIPMENT	
Air Intake	Dual stainless steel 13" Donaldson cowl mtd air cleaners Raised intake stacks - optional
Air Compressor	19.0 CFM single cylinder compressor
Engine Brake	Jacobs compression brake
Engine Fan Drive	Borg Warner (Kysor), option: Horton two-speed Drivemaster
Radiator	1,875 square inch copper/brass
Starter	Mitsubishi Mod 31 75-DP60 with integrated magnetic switch
TRANSMISSION	
Transmission	Eaton Fuller Manual and Ultrashift AMT
AXLE & SUSPENSION	
Front Axle	Meritor MFS-16-122A FL1 (MFS73) 16,000 lb axle capacity Options: Meritor FG-941, 14,600 lb axle capacity Meritor FL941 front axle, 20,000 lb capacity
Front Suspension	Taper-leaf & flat-leaf, 16,000–20,000 lb capacity
Rear Axle	Meritor RT-46-160GP Options: Meritor MX40-14XGP, RT-50-160GP, RT-52-185GP, RT-52-380G Dana Spicer 44,000 to 52,000 lb
Rear Axle Ratio	4.30 – optional based on application
Main Driveline	Meritor RPL 25SD, option: Dana Spicer SPL250HD
Interaxle Driveline	Meritor RPL 20SD, option: Dana Spicer SPL170HD
Inter-axle Lock	As standard
Differential Lockout	Front & rear differential lock – optional based on application
Rear Suspension	AirLiner 46,000 lb Option: Neway AD-ADZ 46,000 lb up to 52,000 lb Tufftrac 40,000 lb up to 52,000 lb Hendrickson Ultimaax / Primaax 46,000 lb up to 52,000 lb
BRAKE SYSTEM	
Anti-Lock (ABS)	WABCO 4S/4M with traction control enhancement
Air Dryer	WABCO system saver HP with integral air governor and heater
Roll Stability Control	Optional WABCO roll stability control - based on application
FRAME	
Frame Rails	5/16" X 3-1/2" X 10-5/8" steel frame, 120ksi; options available up to double channel
Wheelbase	Options from 4,550 mm 180" to 6,445 mm 254"

CHASSIS EQUIPMENT	
Fuel Tanks	25" diameter aluminium, EquiFlo, 604L; options available
Fuel Cooler	Steel core chassis mounted, in frame
WHEELS & TYRES	
Front Tyres	Michelin X Multiway 3D XZE 295/80R22.5 16 ply radial Option: Michelin X Multiway HD XZE 385/65R22.5 20 ply radial
Rear Tyres	Michelin X Multiway D 11R22.5 16 ply radial
Front Rims	Spider hubs with 22.5" x 8.25" steel rims Options: Alcoa aluminium disc wheel 8.25" / 9.00" & 12.25" in aluminium finish, polish & Dura-Bright
Rear Rims	Spider hubs with 22.5" x 8.25" steel rims Option: Alcoa aluminium disc wheels 22.5" x 8.25" in aluminium finish, polish & Dura-Bright
CABIN EXTERIOR	
Cab Size	109" BBC galvanised steel cab, ECE R29 compliant, forward axle
Sleeper	Day cabin Options: 34" Star light low roof sleeper 34" Stratosphere rest cab 40", 54", 68" Stratosphere sleeper high rise stand up cab and walk-through
Primary Mirrors	Moto - dual stainless steel heated left and right-hand motorised mirrors with lights and remote Option: cab mounted - dual Mekra aero bright finish heated dual axis one-piece motorised mirrors with lights, LH and RH remote and integral convex mirrors
Mirror Mtd Aux Mirrors	Left-hand and right-hand 8" convex mirrors, bright finish Dual Mekra bright finish heated convex mirrors with manual adjustment and dual axis for one-piece primary mirrors
Door Window Regulators	Left and right-hand electric powered windows
CABIN INTERIOR	
Heater, Vent, AC	Heater, defroster & air conditioner with constant temperature control & cosmetic cover
INSTRUMENTS & CONTROLS	
Driver Instrument Panel	Woodgrain-like with a premium cherry finish
Driver Info Centre	DataStar driver display and warning lamp/light bar display, non-data linked
PAINT	
Cabin	PPG white with base coat clear - options available
Chassis	PPG single stage - colour options available



**Western Star Trucks is a premier producer of hand-built heavy-duty trucks, engineered for the toughest vocations. To learn more about the different options and the range, contact your local Western Star dealer or visit [WESTERNSTAR.COM.AU](http://WESTERNSTAR.COM.AU)**

**PENSKE AUSTRALIA • 72 FORMATION STREET WACOL QLD 4076 • PHONE (07) 3271 7777**

Dimensions for frame height are all to the top of the chassis above axle (group) centreline and may vary based on frame depth. For illustration purposes different configurations have been used. Due to optional equipment, variable fuel quantity, and therefore tare weight, the variations will occur in the heights. For specific heights please contact your Western Star dealer. On heavy duty trucks, height variations in the order of +/- 25mm can be expected. Heights have been calculated with trucks unladen with Michelin tyres unless specified. Use of tyres by different manufacturers will result in height variations. Contact your Western Star dealer for a full range of options. Specifications may be subject to change.