

# W 4900 EXT

# SPECIFICATIONS

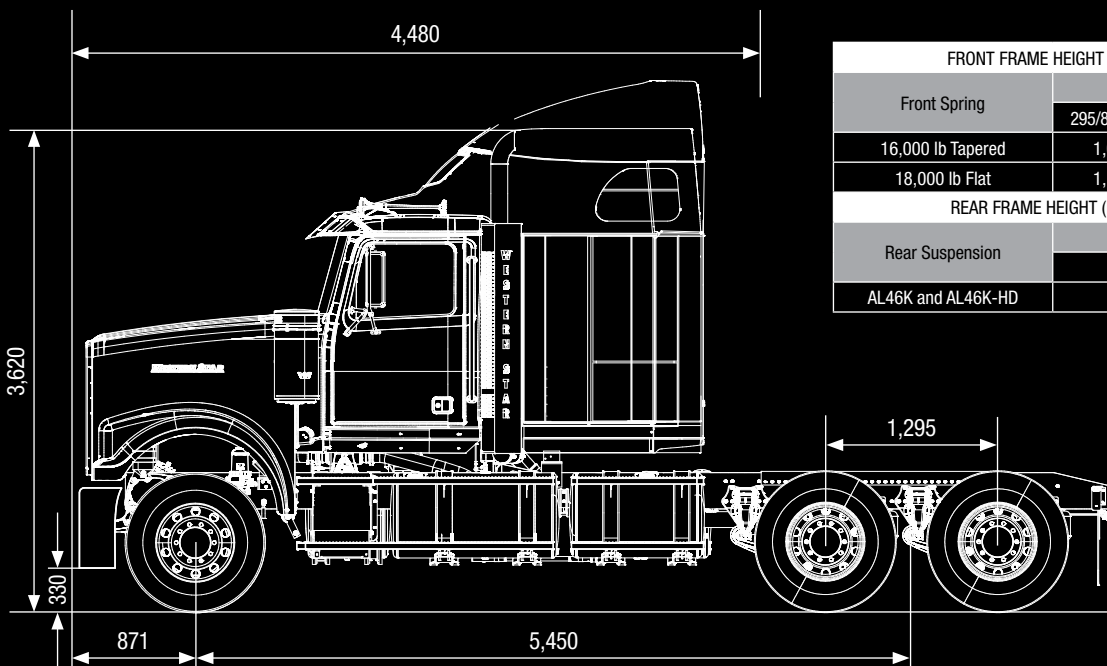

FRONT FRAME HEIGHT (F.F.H) mm		
Front Spring	Tyres	
	295/80R22.5	385/65R22.5
16,000 lb Tapered	1,060	1,065
18,000 lb Flat	1,120	1,125
REAR FRAME HEIGHT (R.F.H) mm		
Rear Suspension	Tyres	
	11R22.5	
AL46K and AL46K-HD	1,060	



# SPECIFICATIONS & OPTIONS

ENGINE	
Engine & HP/RPM, Torque	Detroit DD15 475 hp up to 560 hp, 1,650 lb-ft up to 1,850 lb-ft Option: Cummins X15 550 hp up to 600 hp, 1,850 lb-ft up to 2,050 lb-ft
ENGINE EQUIPMENT	
Air Intake	Dual stainless steel 13" Donaldson cowl mtd air cleaners; Option: raised intake stacks
Air Compressor	DD15 19.0 CFM single cylinder compressor; Option: X15 18.7 CFM single cylinder compressor
Ad Blue Tank Location	X15 – 175L stainless steel tank RHS under door
Engine Brake	DD15 - Jacobs compression brake; Option: X15 - Intebrake compression brake
Engine Fan Drive	Borg Warner (Kysor); Option: Horton two-speed Drivemaster
Radiator	1,875 square inch copper/brass
Starter	DD15 - Mitsubishi Mod 31 75-DP60 with integrated magnetic switch Option: X15 - Delco 12V 39 MT HD/OCP starter with thermal protection
TRANSMISSION	
Transmission	Eaton Fuller manual and Ultrashift AMT
AXLE & SUSPENSION	
Front Axle	Meritor MFS-16-122A FL1 (MFS73) 16,000 lb axle capacity Option: Meritor FG-941, 14,600 lb axle capacity
Front Suspension	16,000lb capacity taper-leaf
Rear Axle	Meritor RT-46-160GP R-series
Rear Axle Ratio	4.30 – optional based on application
Main Driveline	Meritor RPL 25SD; option: Dana Spicer SPL250HD
Interaxle Driveline	Meritor RPL 20SD; option: Dana Spicer SPL170HD
Rear Suspension	AirLiner 46,000 lb capacity
BRAKE SYSTEM	
Anti-Lock (ABS)	WABCO 4S/4M with traction control enhancement
Air Dryer	WABCO system saver HP with integral air governor and heater
Electrical Roll Stability Control	Optional WABCO electrical roll stability control - based on application in the brake system area
FRAME	
Frame Rails	3/8" x 3-1/2" x 10-3/4" steel frame, 120ksi
Wheelbase	DD15 - 5,800mm (228"); Option: X15 - 5,850mm (230")

CHASSIS EQUIPMENT	
Fuel Tanks	25" diameter aluminium, EquiFlo, DD15 1,721L; Option: X15 1,702L
Fuel/Water Separator	DD15 Davco 487 with ESOC; Option: X15 Davco 382
Fuel Cooler	Steel core chassis mounted, in frame
WHEELS & TYRES	
Front Tyres	Michelin X Multiway 3D XZE 295/80R22.5 16 ply Option: Michelin X Multiway HD XZE 385/65R22.5 20 ply radial front tyres
Rear Tyres	Michelin X Multiway D 11R22.5 16 ply
Wheels	Alcoa aluminium disc wheel 8.25" / 9.00" & 12.25" aluminium finish polish & Dura-Bright 8.25" / 9.00" & 12.25"
CABIN EXTERIOR	
Cabin	123" BBC galvanised steel cab, ECE R29 compliant, forward axle
Sleeper	54" Stratosphere sleeper high rise stand up cab and walk-through
Primary Mirrors	Moto - dual stainless steel heated left and right-hand motorised mirrors with lights and remote Option: cab mounted - dual Mekra aero bright finish heated dual axis one-piece motorised mirrors with lights, LH and RH remote and integral convex mirrors
Mirror Mtd Aux Mirrors	Left-hand and right-hand 8" convex mirrors, bright finish Option: dual Mekra bright finish heated convex mirrors with manual adjustment and dual axis for one-piece primary mirrors
Door Window Regulators	Left and right-hand electric powered windows
CABIN INTERIOR	
Heater, Vent, AC	Heater, defroster & air conditioner with constant temperature control & cosmetic cover
INSTRUMENTS & CONTROLS	
Driver Instrument Panel	Woodgrain-like with a premium cherry finish
Driver Info Centre	DataStar driver display and warning lamp/light bar display, non-data linked
PAINT	
Cabin	PPG white with base coat clear - options available
Chassis	PPG single stage - colour options available



WESTERN STAR TRUCKS®

**Western Star Trucks is a premier producer of hand-built heavy-duty trucks, engineered for the toughest vocations. To learn more about the different options and the range, contact your local Western Star dealer or visit [WESTERNSTAR.COM.AU](http://WESTERNSTAR.COM.AU)**

**PENSKE AUSTRALIA • 72 FORMATION STREET WACOL QLD 4076 • PHONE (07) 3271 7777**

Dimensions for frame height are all to the top of the chassis above axle (group) centreline and may vary based on frame depth. For illustration purposes different configurations have been used. Due to optional equipment, variable fuel quantity, and therefore tare weight, the variations will occur in the heights. For specific heights please contact your Western Star dealer. On heavy duty trucks, height variations in the order of +/- 25mm can be expected. Heights have been calculated with trucks unladen with Michelin tyres unless specified. Use of tyres by different manufacturers will result in height variations. Contact your Western Star dealer for a full range of options. Specifications may be subject to change.