

SERIOUS SPECS

W 4900 EXT



Serious trucks.™



WESTERN STAR TRUCKS

W 4900 EXT



Engine Options	Detroit Diesel DD15 EGR 14.8 Litre 560hp Cummins ISX Euro 5 SCR 550, 600hp & Signature EGR 600hp
Engine Brake Options	Jacobs compression brake (Detroit) Cummins InteBrake compression brake
Transmission Options	Eaton Fuller RTLO-20918B to RTLO-22918B 18 speed overdrive manual & ultra-shift Included oil pump, Hayden cooler & oil filter (synthetic lube standard)
Front Axle	Meritor MFS73 available standard Meritor FG941, FL941 options available Forward axle 838mm (33") set-back dimension
Steering	TRW TAS85, 23.3:1 ratio, RHD; TRW pump; 4 quart reservoir; 508mm (20") leather 2-spoke steering wheel with tilt/telescopic column
Front Suspension	Taper leaf rated at 7,500kg (16,600lb) Optional flat leaf 7,500kg (16,600lb) Threaded pins & bushings standard Synthetic lube standard
Front Brakes	WABCO Antilock Braking System (ABS) with traction control Meritor 419mm x 152mm (16½" x 6") available standard Optional Meritor 419mm x 127mm (16½" x 5") FG941 'Q-Plus' cam; automatic slack adjusters Bendix ADB22X Air Disc optional

Rear Axle Options	Meritor RT-46-160GP R-series rear axle, 46,000lb axle capacity Optional Dana D46-170P dual drive rear axle, 46,000lb axle capacity Synthetic lube standard
Rear Brakes	WABCO Antilock Braking System (ABS) with traction control Meritor 419mm x 178mm (16½"x7") 'Q-Plus' cam, automatic slack adjusters & included fabricated HD shoes Bendix ADB22X air disc optional
Main Driveline Options	Meritor RPL25SD heavy duty series, non-greasable Optional Dana Spicer SPL250HD 'XL' with half round yokes
Interaxle Driveline Options	Meritor RPL20 heavy duty series, non-greasable Optional Dana Spicer SPL170 'XL' with half round yokes
Air Compressor Options	BW Model BA-921 19.0 CFM single cylinder compressor with safety valve (Detroit) Cummins 18.7 CFM single cylinder compressor with safety valve
Rear Suspension Options	Airliner 46,000lb capacity rear suspension
Air Cleaner Options	Dual stainless steel 13" Donaldson cowl mounted air cleaners with polished stainless steel bands Dual stainless steel 13" Donaldson cowl mounted with inline separator & extension rams & water resistant element

Fan Clutch	Reinforced nylon fan Borg Warner (Kysor) fan clutch Optional Horton two-speed fan clutch
Oil Filter	Full flow: engine mounted
Radiator Options	1875 square inch, heavy-duty copper/brass radiator core
Exhaust Options	Dual vertical muffler & stack with polished perforated stainless steel exhaust shield with logo; chromed stack & lower elbow; cab mounted with diesel particulate filter
Alternator	Delco Remy 12V 160 AMP, 36 SI Brushless Quadramount pad alternator with remote battery volt sense
Batteries	Alliance model 7T31, Group 31, 12 volt maintenance-free 2920 CCA batteries with threaded studs (DD15) 4 Alliance, Model 7A31, Group 31, 12 volt glass mat 2920 CCA batteries with threaded studs (E5) Positive cab power battery shut-off switch mounted in cab outboard of driver's seat
Starter Options	Delco 12V 39MT/OCP HD Series starter with thermal protection
Clutch	Eaton Fuller 15 1/2" Solo VCT dampened ceramic adjustment-free soft rate clutch, available for engines up to 2250lb-ft torque
Oil Seals	Front & back oil seals; Chicago Rawhide 'Scotseal XL'
Frame Options	⅜" x 3½" x 10¾" single channel rail, 230" (E5) or 228" (DD15) wheelbase
Front Bumper Options	18" chrome bumper, FUPS, 4 or 5-post FUPS bull bar
Air Tank Dryer	1 CR Turbo 2000 air dryer with heater Optional Dual CR Turbo 2000
Air Tank Drain	Bendix Westinghouse DV-2 auto moisture ejector without heater (optional heater available) to wet tank-drain valves on all other tanks
Air Line Piping	Reinforced nylon lines, cab/chassis Optional wire braid chassis lines
Air Tanks	Steel in rail Optional Aluminium



Fuel Tank Options	4 x 473L 25" diameter (DD15), 2x473L, 2x378L 25" diameter (E5) Heavy duty polished stainless steel straps; EquiFlo inboard fuel system 175 litre diesel exhaust fluid tank mounted RHS under cab door (E5) Fuel cooler standard
Battery Box	4 size steel battery box mounted in rail (DD15) Stack 4 size battery box under LHS door cab access (E5)
Cab Shell & Doors	ECE-R29 conforming cab E-Coated galvanised severe service 123" BBC Steel cab with aluminised wax rustproofing; welded construction; exterior fibreglass sunvisor; fibreglass cab skirts; stainless sill plates
Sleeper Cab Options	54" Stratosphere 'walk-through' sleeper Side shields and aero kit options available
Steps	Polished aluminium; safety grip on fuel tanks
Bonnet & Fenders	Sloped tilt fibreglass hood with stainless steel grille bezel with insect screen; radiator mounted aluminium grille; mudflaps behind front tyres
Insulation	Full cab & firewall insulation; cab undercoating; barium/ceramic/foam insulation to floor & toeboard
Grab Handles	LH & RH exterior grab handles mounted to cab LH & RH interior grab handles mounted to A-post
Mirrors	Dual stainless steel primary mirrors, heated with lights, LH motorised (optional LH & RH motorised) door mounted Dual 152mm (6") stainless steel convex auxiliary mirrors mounted below primary mirrors, optional 203mm (8") convex mirrors & 102mm x 229mm (4" x 9") LH mounted downview mirror
Headlamps	Dual 178mm (7") round headlamps, LED optional

Tail Lamps	Dual stop, tail, turn & reversing lamps mounted in stainless steel light bar Optional LED
Marker Lamps	5 amber LED chrome rectangular 2 amber LED chrome rectangular if roof mounted condenser fitted
Courtesy Lamps	Dome, under dash & in both doors
Horns	Dual Hadley 660mm (26") air horns with shields; single tone electric horn Optional single Hadley 26" rectangular air horn Standard Stratosphere specified dual Hadley 22" chromed round airhorns mounted on cab roof Optional dual round air horns, single base, mounted under cab Quad horns Stratosphere - dual 22" chrome round horns & dual 19" chrome round horns
Switches	Three spare accessory switches; wiring & relay for bull lights
Reading Lamps	Adjustable with individual switches in overhead console & above both doors
Trailer Air Valves	Hand control valve; tractor protection valve; light connections, all behind cab or optional EOF
Windows	Clear laminated 2-piece windscreen; tinted optional as well as 1-piece (Australian fit); tinted safety glass side & rear Optional powered RHS & LHS door windows
Heater/Defroster	13.2kW (45,000 BTU) fresh air intake
Air Conditioning	Integrated with radiator mounted condenser Optional Red Dot roof mounted air conditioning condenser
Driver's Seat	Options include National 2000, Bostrom & Isri seats available
Passenger's Seat	Tubular frame, fixed mount; 3-point retractor seat belt Options include National 2000, Bostrom & Isri seats available
Instrument Panel	Cherry simulated standard Optional black panel Optional vinyl 'Woodgrain' in Royal Rosewood available

Interior Trim	Mesa vinyl upholstery package with diamond stitching on door panels and back panel Overhead console with map pockets on driver and passenger side, windshield post covers Soft touch trim on overhead console, windshield post covers, trim above doors & upper door panels; dual interior sunvisors with pocket; moulded overhead console with passenger side storage area; side window defrost ducts & integrated arm rests; document pouch on driver's door; colour-keyed carpet on lower door; rubber floor mats
Instruments & Gauges	Metric primary & secondary air pressure gauges, low air buzzer & lamp, fuel gauge, voltmeter, engine coolant temperature, oil pressure, engine oil temperature, exhaust temperature, rear axle oil temperature, transmission oil temperature, 89mm (3½") diameter speedometer/odometer & 89mm (3½") electronic tachometer with hour meter, Datastar, gauge finish in black bezel or optional silver bezel
Paint	White PPG acrylic urethane to cab & hood basecoat/clearcoat; red chassis, silver rims options include custom paint
Tyres & Wheels	Front tyres: Michelin Multiway 3D XZE 295/80R22.5 16 ply Rear tyres: Michelin X Multiway D 11R22.5 16 ply Alcoa 88364X 22.5" x 8.25 to 12.25, 10-hub piloted, aluminium disc front wheels Alcoa 88364X 22.5 x 8.25 10-hub piloted, aluminium disc rear wheels, optional Ultra 1 Ultrax



Serious trucks.SM

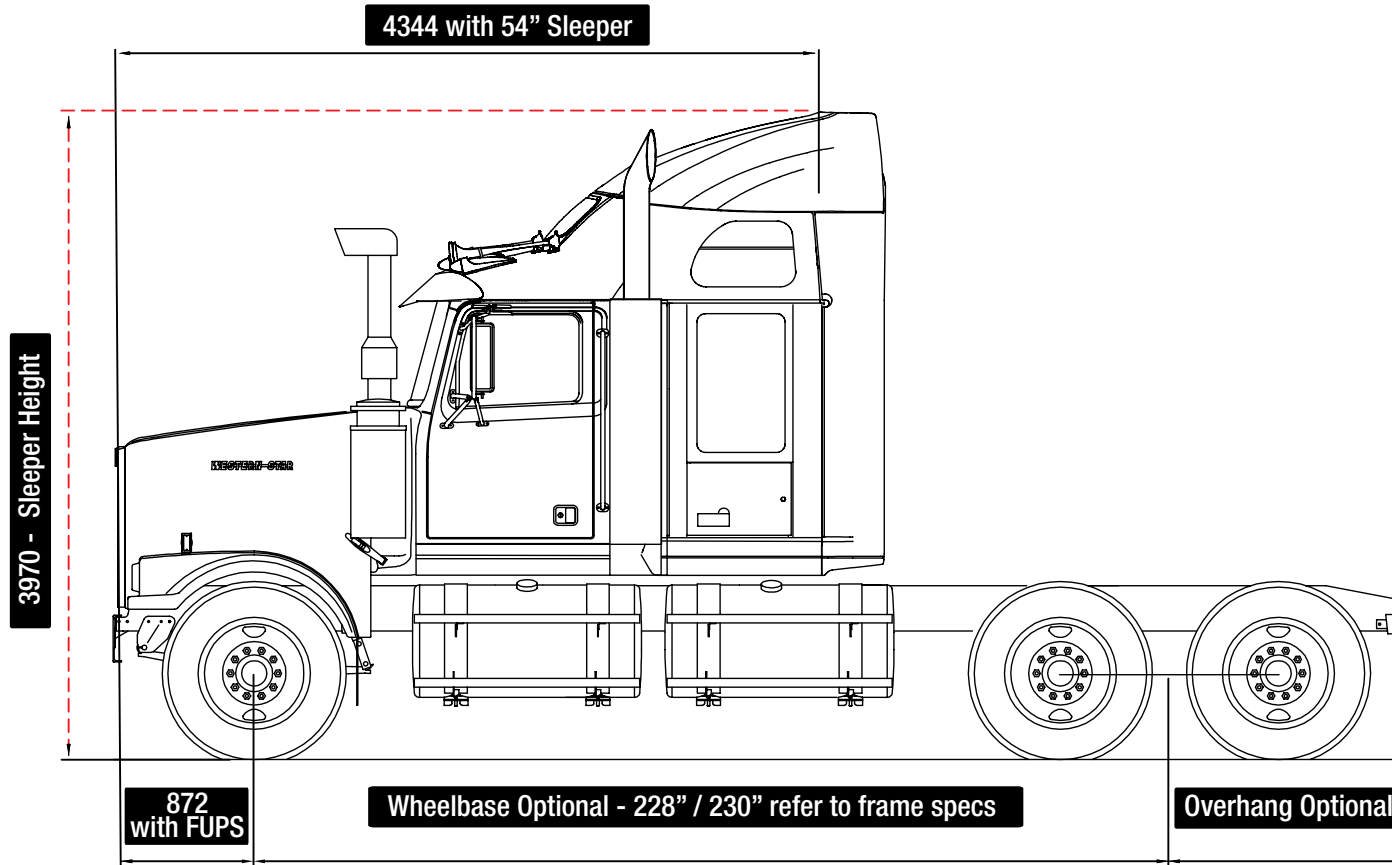

Western Star Trucks Australia

72 Formation Street, Wacol, QLD 4076 ★ PO Box 301, Goodna QLD 4300 ★ Phone: + 61 7 3271 7777 ★ www.westernstar.com.au

Truck photos are for illustration purposes only. Engine and truck specifications are subject to change. 10/15.