

SERIOUS SPECS

W 4800 EXB



Serious trucks.™



WESTERN STAR TRUCKS®



Engine Options	Detroit Diesel DD15 EGR 14.8 litre 530 & 560hp Cummins ISX Euro-5 SCR – 550, 600 & Signature 600hp
Engine Brake Options	Jacobs compression brake (Detroit) Cummins InteBrake compression brake
Transmission Options	Eaton Fuller 18-speed overdrive manual & 18-speed ultra-shift with oil pump & Hayden cooler & oil filter; Synthetic lube standard
Front Axle	Meritor MFS73 Optional FG-941 Forward axle 838mm (33") set-back dimension Synthetic lube standard
Steering	TRW TAS 85, 23.3:1 ratio, RHD; TRW pump; 4 quart reservoir; 508mm (18") wood-leather wrapped 2-spoke steering wheel with tilt/telescopic column
Front Suspension	Taper leaf rated at 7,258kg (16,000lb) total capacity; cast iron spring brackets; threaded pins & bushes standard
Front Brake Options	WABCO Antilock Braking System (ABS) with traction control Meritor 419mm x 127mm (16½" x 6") 'Q-Plus'; Haldex automatic slack adjusters Bendix ADB22X air disc front brakes optional
Rear Axle Options	Meritor RT-46-160GP R-series rear axle, 46,000 lb axle capacity Optional Dana D46-170P dual drive rear axle, 46,000lb axle capacity Synthetic lube standard

Rear Brakes	WABCO Antilock Braking System (ABS) with traction control Meritor 419mm x 178mm (16½" x 7") 'Q-Plus' cam with MGM chambers, automatic slack adjusters Bendix ADB22X air disc rear brakes
Main Driveline Options	Dana Spicer SPL250HD 'XL' main driveline with half round yokes Meritor RPL25SD main driveline. Non-greasable
Interaxle Driveline Options	Dana Spicer SPL170 'XL' interaxle driveline, half round yokes Meritor RPL20 interaxle driveline. Non-greasable
Rear Suspension Options	Airliner 46,000lb capacity rear suspension
Air Compressor Options	BW Model BA-921 19.0 CFM single cylinder compressor with safety valve (Detroit) Cummins 18.7 CFM single cylinder compressor with internal safety valve
Oil Filter	Full flow oil filter
Air Cleaner Options	Dual stainless steel 13" Donaldson cowl mounted air cleaners with polished stainless steel bands Dual stainless steel 13" Donaldson cowl mounted with inline separator & extension rams & water-resistant element
Fan Clutch	Reinforced nylon fan. Borg Warner (Kysor) fan clutch Optional Horton two-speed fan clutch
Radiator	1875 square inch copper/brass radiator

Exhaust Options	Stationary cab/sleeper mounted, dual vertical exhaust with polished stainless steel exhaust shield, chromed stack & lower elbow with diesel particulate filter
Alternator	Delco Remy 12V 160 Amp, 36 SI brushless Quadramount pad alternator with remote battery volt sense
Batteries	Alliance Model 7A31, Absorbed glass mat, Group 31, 12 volt maintenance-free 2920 CCA batteries with threaded studs; Positive cab power battery shut-off switch mounted in cab, outboard of driver's seat
Starter Options	Delco 12V 39 HD/OCP series starter with terminal protection for Detroit engines
Clutch	Eaton Fuller 15½" Solo VCT dampened ceramic adjustment-free soft rate clutch
Oil Seals	Chicago Rawhide Scotseal Plus XL front and rear oil seals
Frame Options	4950mm (195" with 34" stratosphere only) wheelbase (DD15) 5100mm (201" with 40" stratosphere only) wheelbase (DD15 & E5) 5450mm (215" with 54" stratosphere only) wheelbase(DD15 & E5)
Overhang	1400mm (55")
Front Bumper Options	FUPS bumper, optional 18" chromed steel bumper, 18" chromed steel bumper with FUPS mechanism and cover and FUPS bull bar
Air Tank Dryer	CR Turbo 2000 (Model 65) air dryer with heater Air Tank Drain Bendix Westinghouse DV-2 auto moisture ejector without heater to wet tank Drain valves on all other tanks
Air Line Piping	Reinforced nylon lines, cab & chassis
Battery Box	Steel (4) battery size battery box mounted under sleeper bunk (DD15) Stack 4 size steel battery box under LHS door cab access (E5)
Air Tanks	Steel in rail, perpendicular if required



Fuel Tank Options	4 x 453 litre (201" – 26" diameter, dual draw) (DD15) 3 x 378, 1 x 302 litre (195" – 25" diameter, EquiFlo) (DD15) 4 x 473 litre (215" – 25" diameter, EquiFlo) (DD15) 2 x 378, 2x302 litre (201" – 25" diameter, EquiFlo) (E5) 2 x 473, 2 x 302 litre (215" – 25" diameter, EquiFlo) (E5) 150 litre diesel exhaust fluid tank mounted RHS under door cab access (E5)
Cab Shell & Doors	ECE-R29 conforming cab E-Coated galvanised severe service 109" BBC steel cabs with aluminised wax rustproofing; welded construction; exterior fibreglass sunvisor; fibreglass cab skirts; stainless sill plates
Sleeper Cab Options	Starlight sleeper in a 34" low roof configuration (DD15) Stratosphere 'walk-through' sleeper available in a 34" (DD15), 40" or 54" (DD15 & E5) configuration Side shield standard & aero kit options available
Steps	Polished aluminium; safety grip on fuel tanks
Bonnet & Fenders	Sloped tilt fibreglass hood with stainless steel grille bezel with insect screen; radiator -mounted aluminium grille; mudflaps behind front tyres
Insulation	Full cab & firewall insulation; cab undercoating; barium/ceramic/foam insulation to floor & toeboard
Grab Handle	LH & RH exterior grab handles mounted to cab LH & RH interior grab handles mounted to A-post
Mirrors	Dual stainless steel primary mirrors, heated with lights, LH motorised (optional LH and RH motorised) door mounted Dual 152mm (6") stainless steel convex auxiliary mirrors mounted below primary mirrors, optional 203mm (8") convex mirrors 102mm x 229mm (4" x 9") LH mounted downview mirror standard

Headlamps	Dual 178mm (7") round headlamps, optional LED
Tail Lamps	Dual stop, tail, turn & reversing lamps
Marker Lamps	LED amber rectangular, optional LED chrome bullet
Courtesy Lamps	Dome, under dash & in both doors
Switches	Three spare accessory switches; wiring & relay for bull lights
Reading Lamps	Adjustable with individual switches in overhead console & above both doors
Horns	Dual Hadley 22" chromed round airhorns mounted on cab roof Optional dual round air horns, single base, mounted under cab Quad Horns - Dual 22" chrome round horns & dual 19" chrome round horns
Trailer Air Valves	Hand control valve; tractor protection valve; light connections, all behind cab
Air Conditioning	Integrated with radiator-mounted condenser
Windows	Clear laminated 2-piece windscreen; tinted optional as well as 1-piece (Australian fit); tinted safety glass side & rear
Heater/Defroster	13.2kW (45,000 BTU) fresh air intake
Interior Trim	Mesa vinyl upholstery package with diamond stitching on door panels and back panel Soft touch trim on overhead console, windshield post covers, trim above doors & upper door panels; dual interior sunvisors with pocket; moulded overhead console with passenger side storage area; side window defrost ducts & integrated arm rests; driver & passenger side map pockets & rubber floor mats

Instruments & Gauges	Metric primary & secondary air pressure gauges, low air buzzer & lamp, fuel gauge, voltmeter, engine coolant temperature, oil pressure, engine oil temperature, exhaust temperature, rear axle oil temperature, transmission oil temperature, 89mm (3½") diameter speedometer/odometer & 89mm (3½") electronic tachometer with hour meter, Datastar, gauges available in silver bezel finish
Instrument Panel	Cherry simulated standard Optional black panel Optional vinyl 'Woodgrain' in Royal Rosewood available
Driver's Seat	National 2000 high back: 3-point retractor seat belt; driver's seat armrests Optionals include National 2000, Bostrom & Isri seats available
Passenger's Seat	Tubular frame, fixed mount; 3-point retractor seat belt Optionals include National 2000, Bostrom & Isri seats available
Paint	White PPG basecoat/clearcoat acrylic urethane to cab & hood; red chassis Options include custom paint
Tyres & Wheels	Front tyres: Michelin Multiway 3D XZE 295/80R 22.5 16 ply Rear tyres: Michelin X Multiway D 11R 22.5 16 ply Alcoa 88364X 22.5 x 8.25 to 12.25", 10-hub piloted, aluminium disc front wheels Alcoa 88364X 22.5 x 8.25 10-hub piloted, aluminium disc rear wheels, optional Ultra 1 Ultrax disc wheels



Serious trucks.SM

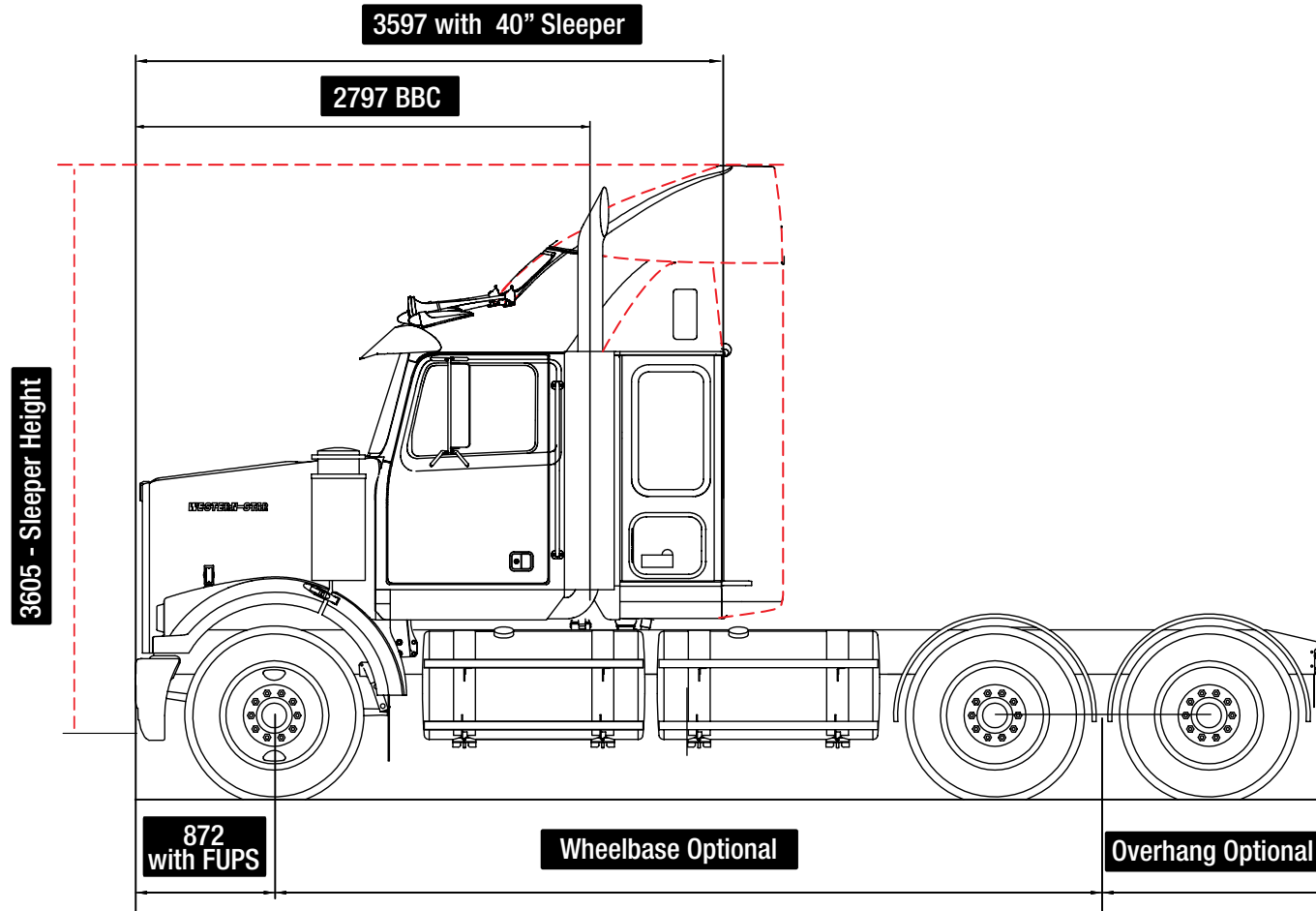

Western Star Trucks Australia

72 Formation Street, Wacol, QLD 4076 ★ PO Box 301, Goodna QLD 4300 ★ Phone: + 61 7 3271 7777 ★ www.westernstar.com.au

Truck photos are for illustration purposes only. Engine and truck specifications are subject to change. 10/15.