

SERIOUS SPECS

W4700SB



Serious trucks.™



WESTERN STAR TRUCKS®

W4700SB



Engine	Cummins ISL 8.9 litre 280-360HP @ 2100 rpm, 780-1100ft-lb @ 1100-1300 rpm
Engine Brake	C-brake by Jacobs with low/off/high braking and dash switch
Transmission	Allison Automatic 3000 RDS with PTO provision, 6 speed, Optional 3500 RDS with PTO provision (based on engine)
Front Axle	Dual steer - Meritor MFS-14-143A FF1 13.4t (29,400 lb.)
Steering	TRW THP-60 power steering with RCH60 auxiliary gear
Front Suspension	Taper leaf 13.2t (29,200 lb.) dual steer
Front Brake	WABCO Antilock Braking System (ABS), Automatic slack adjusters, Meritor 419mm x 127mm (16"x5") Q plus cast spider, double anchor, optional traction control enhancement
Air Compressor	Cummins 18.7 CFM single cylinder compressor with internal safety valve
Rear Axle Options	Dana Spicer DSH-44P 20t (44,000 lb.), Meritor RT-46-160GP R-Series 20.9t (46,000 lb), with optional driver control traction control
Rear Brakes	WABCO Antilock Braking System (ABS), Meritor 419mm x 178mm (16" x 7") Q-Plus cast spider cam, Automatic slack adjusters

Main Driveline	Meritor MXL 17N extended lube main driveline with full round yokes
Interaxle Driveline	Meritor MXL 17N extended lube interaxle driveline with full round yokes
Rear Suspension Options	Airliner Tandem Drive 20.9T (46,000 lb), optional Tuf-Trac Tandem Drive 20.9T (46,000 lb.)
Oil Filter	Full flow
Air Cleaner	Side of hood air intake with firewall mounted air cleaner
Fan Clutch	Horton 2-speed drivemaster on/off engine fan clutch
Radiator	1300 square inch aluminium
Exhaust	Vertical LH outboard frame mounted vertical SCR device with single vertical exhaust FVB
Alternator	Delco Remy 12V 160 amp, 36 SI brushless quadramount pad alternator with remote battery volt sense
Batteries	(3) Alliance Model 1231, Group 31, 12 volt maintenance-free 3300 CCA batteries with threaded studs, optional (2) at 2200 CCA

Starter	Delco Remy 12V 39MT HD/OCP starter with thermal protection
Oil Seals	Chicago Rawhide Scotseal Plus XL
Frame	Heat treated steel alloy 120 KSI, 8.73mm x 258.8mm / 0.344 x 10.19" (1 ¹ / ₃₂ " x 3 ¹ / ₂ " x 10 ³ / ₁₆ "); 5450mm (215") wheelbase
Front Bumper	Alloy bumper with front underrun protection (FUPS)
Air Tank Dryer	CR Brakemaster Turbo 2000 (model 65) air dryer with heater
Air Tanks	Aluminium air tanks mounted aft inside and/or below frame just forward of rear suspension
Air Tank Drain	Bendix Westinghouse DV-2 auto drain valve without heater to wet tank – drain valve cables on all other tanks
Air Line Piping	Reinforced nylon, fabric braid and wire braid chassis lines with test ports
Fuel Tank	LHS 189 litre aluminium fuel tank 23" and 25" diameter (227 litre optional)



Battery Box	Stack battery box mounted under right hand side cab access
Cab Shell & Doors	ECE-R29 conforming cab E-Coated galvanised severe service, 110" BBC steel cab with aluminised wax rustproofing; welded construction; exterior fibreglass sunvisor (optional stainless steel); fibreglass cab skirts; stainless sill plates
Steps	Bare aluminium; safety grip, optional polished
Bonnet & Fenders	Sloped tilt fibreglass hood with chrome steel grille bezel with insect screen; radiator mounted aluminium grille; mudflaps behind front tyres, lower radiator guard
Insulation	Additional cab sidewall insulation, with under cab floor and toeboard insulation
Grab Handle	LH & RH exterior grab handles mounted to cab LH & RH interior grab handles mounted to A-post
Mirrors	Dual west coast bright finish heated with lights, optional Dual Moto stainless steel heated LH motorized with lights and remote, Dual Moto stainless steel heated LHS & RHS motorized with lights and remote
Headlamps	Single rectangular halogen headlights with bright bezels
Tail Lamps	Nu-Line stainless steel mud flap bracket 31" long with isolator, Truck-Lite 3 chamber module with 45 series sealed beam lamps
Marker Lamps	LED marker lights rectangular
Courtesy Lamps	Dome, under dash & in both doors

Horns	Single Hadley 660 mm (60") rectangular air horn, optional dual rectangular Hadley 660mm (26") air horns with shields; single tone electric horn with shields
Switches	Optional on/off rocker switches in numerous quantities with/without lamps and wiring
Reading Lamps	Adjustable with individual switches in overhead console & above both doors
Windows	Clear laminated 2-piece windshield; tinted optional as well as 1-piece (Australian fit); tinted safety glass side & rear; powered LHS door window; optional powered dual RHS & LHS door windows
Heater/Defroster	13.2kW (45,000 BTU) fresh air intake
Air Conditioning	Integrated with radiator mounted condenser, optional red dot roof mounted air conditioning condenser
Interior Trim	Stitching on door panels and back panel. Mesa vinyl upholstery package with diamond, soft touch trim on overhead console, windshield post covers, trim above doors and upper door panels; dual interior sunvisors with pocket; moded overhead console with passenger side storage area; side window defrost ducts & integrated arm rests; driver and passenger side map pockets and rubber floor mats
Driver's Seat	National 2000 Series, high back, driver's seat with active air lumbar support; Optional ISRI 6860 driver's seat
Passenger's Seat	Tubular frame, fixed mount; 3-point retractor seat belt, options include National 2000

Instrument Panel	Black panel, optional woodgrain in Cherry Simulated, vinyl woodgrain in Royal Rosewood
Instruments & Gauges	Metric primary & secondary air pressure gauges, low air buzzer & lamp, fuel gauge, voltmeter, engine coolant temperature, oil pressure, engine oil temperature, exhaust temperature, rear axle oil temperature, transmission oil temperature, 89mm (3½") diameter speedometer/odometer & 89mm (3½") electronic tachometer with hour meter, Datastar Gauge finish in Black or optional Silver
Paint	White PPG acrylic urethane to cab & hood basecoat/clearcoat; black chassis, options include custom paint colours and designs
Tyres & Wheels	Michelin X Multiway 3D XZE 295/80R22.5 radial front tyres, Michelin X Multiway D 11R22.5 16 ply radial rear tyres Alcoa 22.5" x 8.25" 10 hub piloted aluminium disc wheels; Optional Alcoa Ultrax 1 disc wheels and Dura-bright wheel finish



Serious trucks.SM

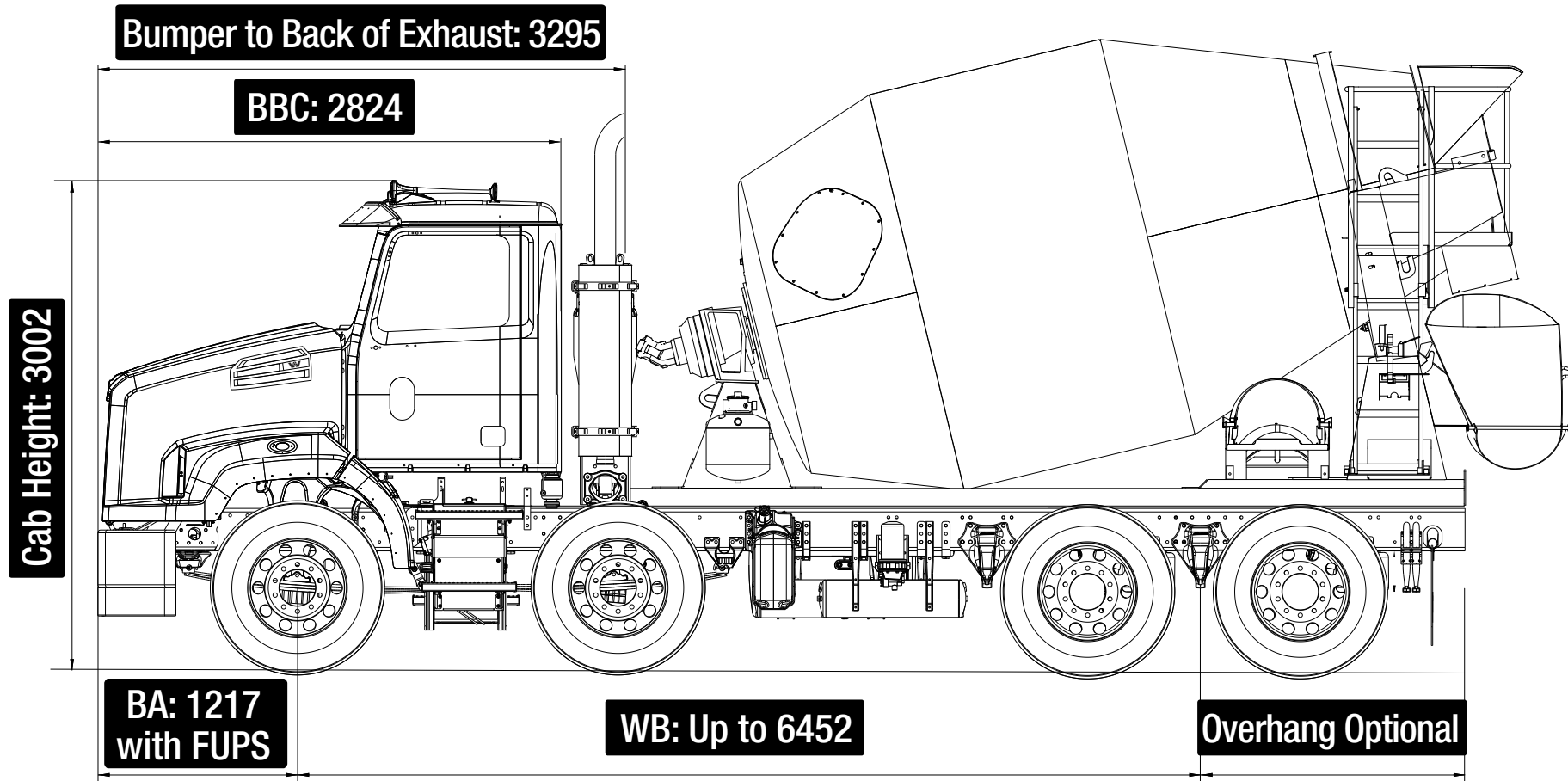

Western Star Trucks Australia

72 Formation Street, Wacol, QLD 4076 ★ PO Box 301, Goodna QLD 4300 ★ Phone: + 61 7 3271 7777 ★ www.westernstar.com.au

Truck photos are for illustration purposes only. Engine and truck specifications are subject to change. 10/15.